



SP228 Manual

CONTENT

Part 1: Operation instruction

General information	1
Product description	2
System description.....	4
Function description.....	10
Fault message	15

Part 2: Installation instruction

General information	17
Mounting.....	18
Electrical wiring.....	19
Commissioning.....	20
Replacing pump.....	21
Packing list.....	23

Part 1: Operation instruction

. General information

1. About this manual

This manual describes the installation, function and operation of an integrated solar work station, which is suitable for split pressurized solar heating system. Before installing and operating the device, please read the following information carefully.

2. Safety regulations

- ◆ Installation, commissioning and maintenance of the device may only be performed by professional personal.
- ◆ All operations that require opening the device are only to be conducted cleared from the power supply. All safety regulations for working on the power supply are valid.
- ◆ The device must not be installed in rooms where easily inflammable material (e.g. gas or oil) mixtures are present or may occur.
- ◆ Before connecting the work station, make sure that the energy supply matches the specifications of the device. Protect the solar station against overloading and short-circuiting.
- ◆ All devices connected to the work station must conform to the technical specifications of the device.
- ◆ As soon as it becomes evident that safe operation is no longer possible, please immediately take the device out of operation.
- ◆ Without lightning rod, please don't use this device during a thunderstorm.

3. Liability waiver

- ◆ Improper installation or operation can cause damages to material and persons. The manufacturer cannot monitor the compliance with these instructions or the circumstances and methods used for installation, operation, utilization and maintenance of this device. Damage by mishandling or improper installation on customer site is immediately leading to warranty exclusion.
- ◆ As faults can never be excluded, we don't offer a guarantee for the completeness of the drawings and texts of this manual, they only represent some examples. They can only be used on own risk. No liability is assumed for incorrect, incomplete or false information and the resulting damages.
- ◆ The manufacturer preserves the right to put changes to product, technical data or installation and operation instructions without prior notice.

4. Symbols used



Danger: Failure to observe these instructions can lead to injury of persons or safety risks.



Attention: Failure to observe these instructions can result in damage to the product or environment.



Note: Useful information and instructions.



Operation steps: Indication of operation steps.

. Product information

1. Components

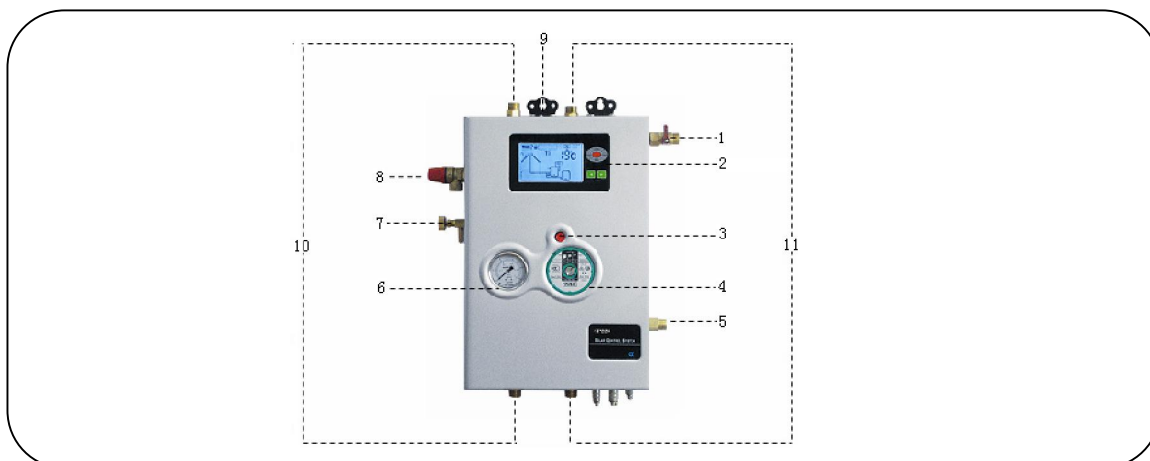



















No	Components	Function description
1	Filling and flushing connector	Through this connector medium can be pumped into solar system
2	Operating screen (LCD)	Display operating menu.
3	Pump speed regulation	Three speed levels available, offers different flow rate.
4	Circulation pump	WILO Star RS 15/6 (110V or 220V)
5	Expansion vessel connector	Connect expansion vessel. Expansion vessel balances the system pressure.
6	Manometer	Display system pressure (Max. 10 bar, normal working pressure is approx. 2 bar)
7	Air vent valve	Empty the air in the solar system
8	Security valve	Protect the system against over-pressure.
9	Mounting point	For fixing the solar pump station
10	Forward flow	Copper material, left side, Max. working temperature 150 , screw thread 1/2' (DN15) as standard
11	Return flow	Copper material, right side. Max. working temperature 150 , screw thread 1/2' (DN15) as standard

2. Technical data

Dimension	450x310x150mm
Input voltage	200V ~ 240V AC or 100V ~ 120V AC
Power	3W
Accuracy of temperature measuring	±1
Range of temperature measuring	PT1000 : 0 ~ 199 NTC10K: 0 ~ 99
Input signals	2 x PT1000 sensor temperature probe 500 , silicon cable 280 ; 4 x NTC10K sensor temperature probe 135 , PVC cable 105

Output signals	1 x Auxiliary heating output (Max. load current: 15A) 4 x Relay output (Max. load current: 3A)
System design pressure	10 bar
Safety valve response pressure	6 bar
WILO pump	SR15/6
Ambient temperature	-10~50
Water protection grade	IP40

3. Display signals

 Week	Weekday: 7 days of week can be set (e.g. Week 1 means "Monday").
	Time: Setting hours and minutes.
	Time-controlled auxiliary heating: Setting three heating time periods.
	Time-controlled hot water circulation: Setting three time periods.
	Storage temperature: As turning-on/off temperature value for auxiliary heating.
	Solar system indication. 8 systems are available.
	Frost protection.
	Temperature-controlled circulation function
	Overheating protection for storage.
	High temperature protection for solar collector.
	Holiday function.
	Switch on/off auxiliary heating manually.
	Forbid/permit using auxiliary heating.
	Reset.
	Extended temperature-difference circulation function
	Recirculating the system through by-pass
	Temperature display.
	Flow rate display.

System description (8 systems available)



Danger: If there is only one temperature sensor in water storage (usually in bottom part T2), it is possible, and that the auxiliary heating function will not be activated or deactivated at a right time, because the water temperature in top part of the storage (T3) cannot be measured. In this case, if you still want to use auxiliary heating function, control program will automatically take the signal from bottom temperature sensor (T2) instead of T3. However, water in top part of storage might often be overheated. It may cause damages to material and persons. So it is highly recommended not to use auxiliary heating in such a case.



Note: To lock this function, please press “Choose Function” button until the signal “” appears on the screen (see details in **8 Forbid/Permit auxiliary heating**).

1. System 1: 1 collector array – 1 storage – 1 pump

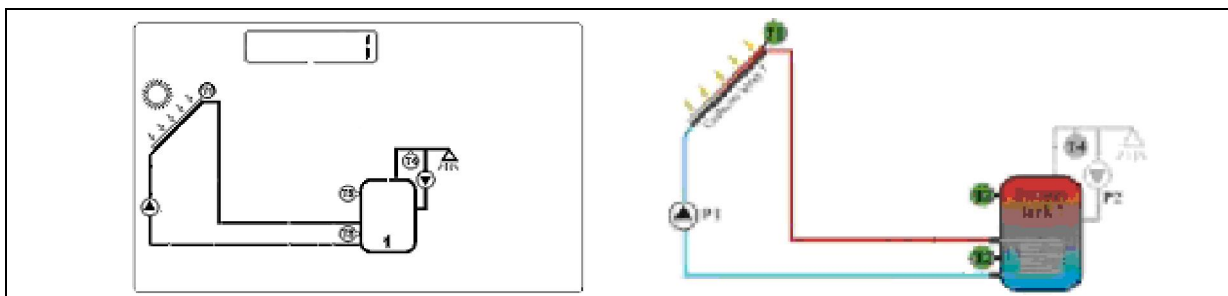

Description:

The solar collector pump (P1) is activated as soon as the temperature difference between the collector array (T1) and the storage (T2) is reached. When the temperature difference between T1 and T2 drops below the switch-off temperature difference, or the storage (T3) reaches its maximum storage temperature, the solar pump (P1) will be switched off.

T3 is used to measure the temperature of the top part of storage. If the turning-on condition for auxiliary heating is filled, the auxiliary heating will be activated

T1: Temperature sensor for collector 1

T2: Temperature sensor in the bottom part of storage 1

T3: Temperature sensor in the top part of storage 1

T4: Temperature sensor for hot water pipe

P1: Solar collector pump

P2: Solar circulation pump

Note:

1. T3, T4, P2 are suitable for system 1-8.
2. T3 is alternative, when no sensor (T3) is installed in the top part of tank, control system will use the signal of sensor T2 automatically to control the auxiliary heating.

2. System 2: 1 collector array – 2 storage – 2 pumps

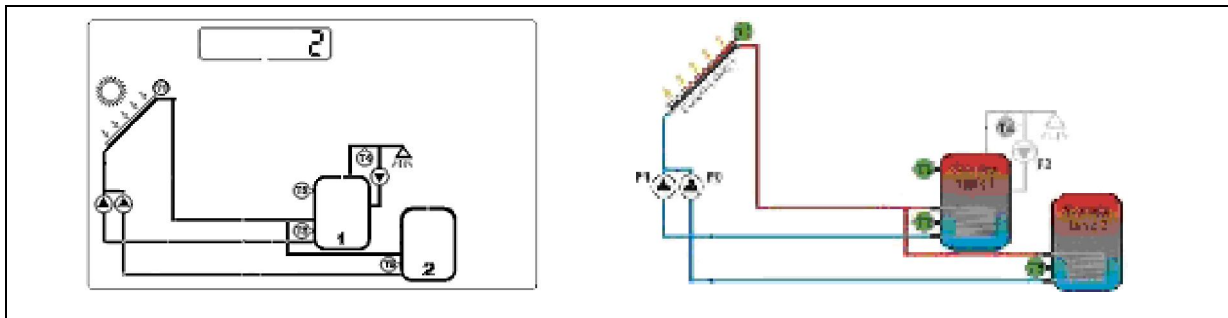

Description:

When switch-on temperature difference between collector array (T1) and one of the storage (T2 or T5) is reached, the solar circuit pump (P1) or (P0) will be switched on. According to the priority switching, two storages (T2, T5) will be loaded one by one. Until either of switch-off temperature difference between collector array (T1) and storage (T2, T5) is reached, or the maximum storage temperature is reached, pump stops working.

T1: Temperature sensor for collector 1

T2: Temperature sensor in the bottom part of storage 1

T3: Temperature sensor in the top part of storage 1

T4: Temperature sensor for hot water pipe

T5: Temperature sensor in storage 2

P0: Solar collector pump

P1: Solar collector pump

Note:

The default priority storage is storage 1.

3. System 3: 1 collector array – 2 storages– 1 pump – 1 valve

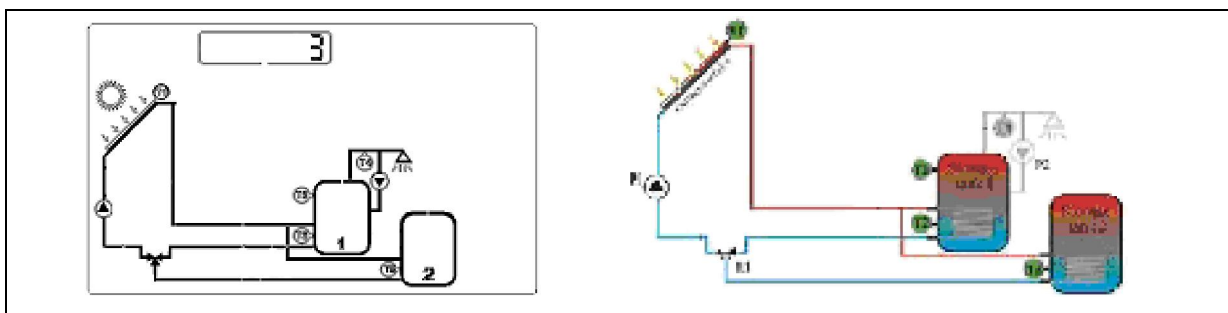

Description:

When switch-on temperature difference between collector array (T1) and one of the storage (T2 or T5) is reached, then the solar pump (P1) is switched on and valve (R1) is set to the correct position depending on the storage to be loaded. According to the priority switching, both storages (T2, T5) will be loaded one by one, until the relevant switch-off temperature difference between the collector array (T1) and storage are reached.

(T2, T5) is reached or the maximum storage temperature of T2 or T5 is reached, pump and valve stop working.

T1: Temperature sensor for collector 1
 T2: Temperature sensor in the bottom part of storage 1
 T5: Temperature sensor in the bottom part of storage 2
 P1: Solar collector pump
 R1: Electromagnetic 3-way valve

Note:

1. When there is no power in the system, the electromagnetic valve (R1) must be set to storage (T2).
2. The default priority storage is storage 1.

4. System 4: 2 collector arrays – 1 storage tank – 2 pumps

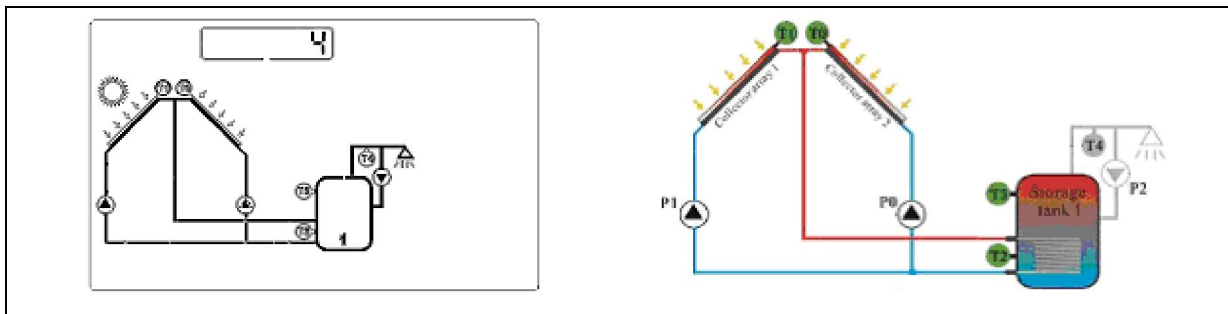

Description:

When switch-on temperature difference between storage (T2) and collector array (T1, T0) is reached, then solar pump (P1) for collector array 1 (T1) or solar circuit pump (P0) for collector array 2 (T0) is switched on, depending on where the temperature difference occurs firstly. If the switch-on temperature difference is reached for both collector arrays (T1, T0), then both pumps (P1, P0) are switched on. The pumps switch-off independently for each other. When either of relevant switch-off temperature difference between one or both collector arrays (T1, T0) and the storage (T2) falls below the threshold or the maximum storage temperature is reached, then the corresponding circuit pump is switched off.

T0: Temperature sensor for collector 2
 T1: Temperature sensor for collector 1
 T2: Temperature sensor in the bottom part of storage1
 P0: Solar collector pump
 P1: Solar collector pump

5. System 5: 2 collector arrays – 1 storage – 1 pump – 1 valve

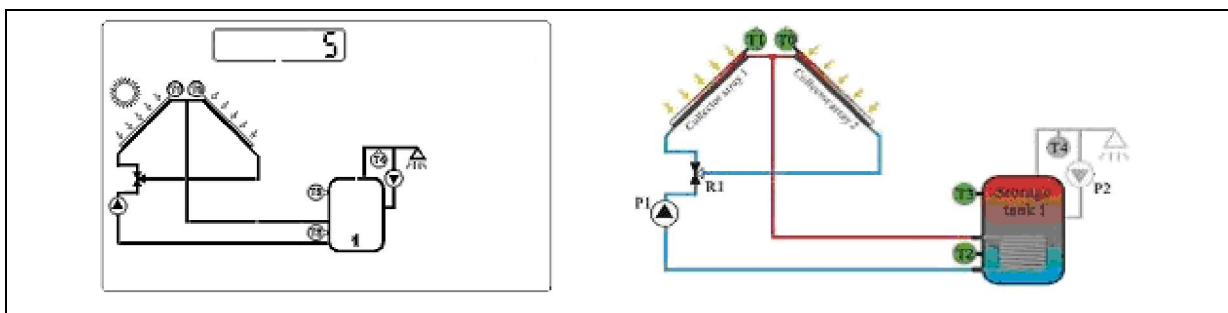

Description:

The solar pump (P1) is switched on as soon as the switch-on temperature difference between one of the two collector arrays (T1, T0) and storage 1 (T2) is reached, the valve R1 is always set so that flow occurs through the warmer of the two collector arrays (T1, T2). The pump P1 switch-off as soon as the switch-off temperature difference between two collector arrays (T1, T0) and storage (T2) is reached or the maximum storage temperature is reached.

T0: Temperature sensor for collector 2

T1: Temperature sensor for collector 1

T2: Temperature sensor in the bottom part of storage 1

P1: Solar collector pump

R1: Electromagnetic 3-way valve

Note:

When there is no power in the system, the electromagnetic valve (R1) must be set to collector array 1.

6. System 6: 2 collector arrays – 2 storages – 1 pump – 2 valves

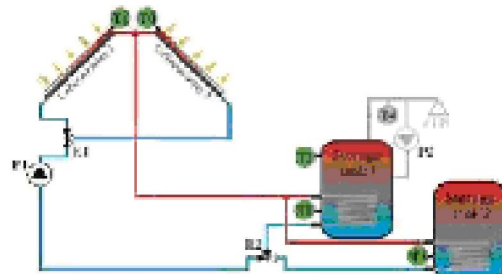
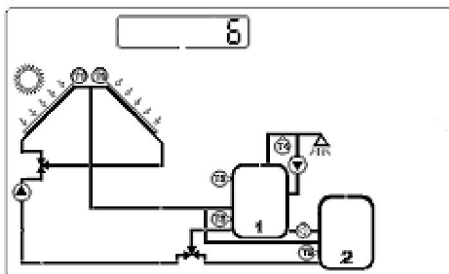

Description:

When switch-on temperature difference between two storage (T2, T5) and collector array 1 (T1) or collector array 2 (T0) is reached, then the solar circuit pump (P1) is switched on, electromagnetic valve (R2) switches the relevant storage into the solar circuit, and electromagnetic valve (R1) switches the affected collector array (T1 or T2) into the solar circuit. Pump (P1) stops working when the switch-off temperature difference between either or both collector arrays and its corresponding storage 1 (T2) and storage 2 (T5) falls below the threshold or the maximum storage temperature (T2 or T5) is reached.

T0: Temperature sensor for collector 2

T1: Temperature sensor for collector 1

T2: Temperature sensor in the bottom part of storage 1

T5: Temperature sensor in the bottom part of storage 2

P1: Solar collector pump 1

R1: Electromagnetic 3-way valve

R2: Electromagnetic 3-way valve

Note:

1. When there is no power in the system, the electromagnetic valve (R2) must be set to storage 1 (T2), the electromagnetic valve (R1) must be set to collector array 1 (T1).
2. Default priority tank is storage 1.

7. System 7: 2 collector arrays – 2 storages – 2 pumps – 1 valve

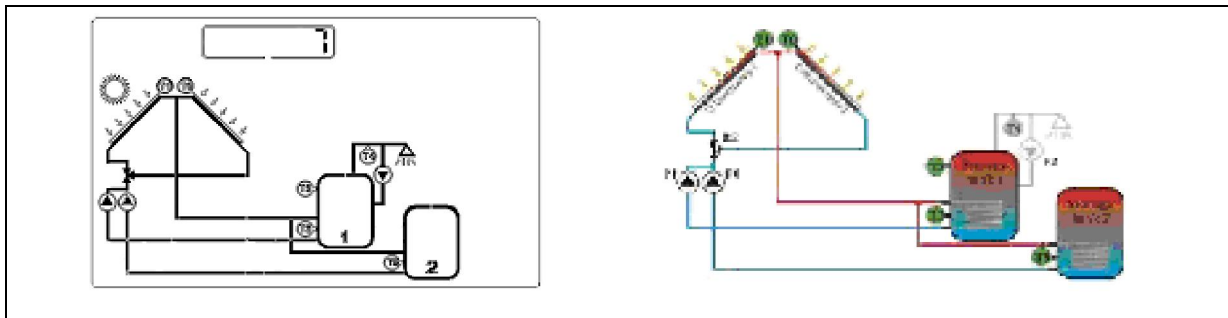

Description:

When switch-on temperature difference between one of the two storages (T2, T5) and collector array 1 (T1) or collector array 2 (T0) is exceeded, then the switching valve R2 switched the corresponding collector array (T1 or T0) into the solar circuit. Depending on which storage has reached the switch-on temperature, solar pump (P1) for storage 1 (T2) or solar pump (P0) for storage 2 (T5) is switched on. The switching valve R2 is always set so that flow occurs through the warmer of the two collector arrays. Both storages (T2, T5) will be loaded one by one, according to the priority switching, until either the relevant switch-off temperature difference falls below the threshold, or the maximum storage temperature (T2 or T5) is reached.

T0: Temperature sensor for collector 2

T1: Temperature sensor for collector 1

T2: Temperature sensor in the bottom part of storage 1

T5: Temperature sensor in the bottom part of storage 2

P0: Solar collector pump

P1: Solar collector pump

R2: Electromagnetic 3-way valve

Note:

1. When there is no power in the system, the electromagnetic valve (R2) must be set to collector array 1(T1).
2. Default priority storage is storage 1.

8. System 8: 2 collector arrays – 2 storages – 2 pumps – 1 valve

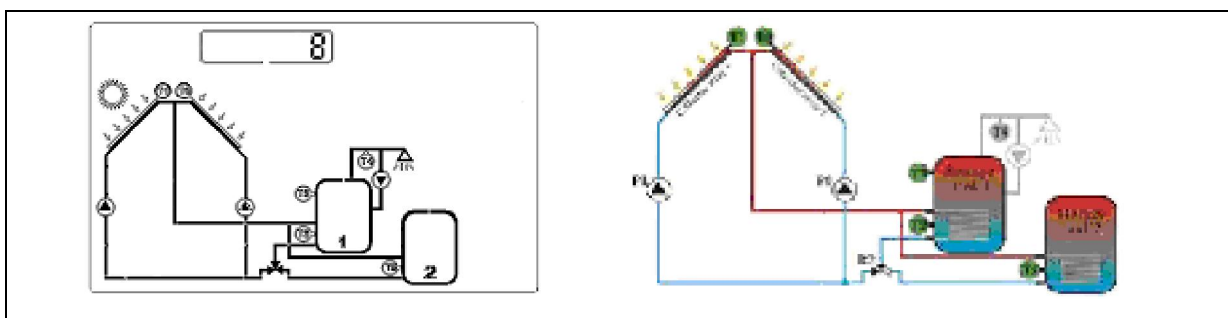

Description:

When switch-on temperature difference between one of the two storage (T2, T5) and collector array1 (T1) and collector array2 (T0) is reached, then the switching valve (R2)

switches relevant storage (T2, or T5) to the solar circuit. Then either solar circuit pump P1 for collector array 1 (T1) or solar circuit pump P0 for collector array 2 (T0) is switch-on, Depending on where the temperature difference occurs. If the switch-on temperature difference is reached between collector arrays (T1, T0), then both pumps (P1, P0) are switch-on. Pump (P1, P0) switch-off independently of each other, when both of relevant switch-off temperature difference between collector arrays (T1, T0) and relevant storage (T2 or T5) falls below the threshold, or the maximum storage temperature is reached.

T0: Temperature sensor for collector 2

T1: Temperature sensor for collector 1

T2: Temperature sensor in the bottom part of storage 1

T5: Temperature sensor in the bottom part of storage 2

P0: Solar collector pump 2

P1: Solar collector pump 1

R2: Electromagnetic 3-way valve

Note:

1. When no power is in the system, the electromagnetic valve (R2) must be set to storage 1 (T1).
2. Default priority storage is storage 1.

Functions and operation



Danger: Before connecting the power supply, make sure that the storage, solar collector, solar work station and all temperature sensors are good connected!



Note: For safety, auxiliary heating is locked at delivery state. The single “” displays on the screen. If you want to use this function, please see operation: **8. Forbid/Permit using auxiliary heating.**

1. Setting week and time

After power supply is switched on, please firstly set the time of the system.

- ì Press “System Setting” button until the signal “Week” display on the screen.
- ì Press “◀” “▶” button to set weekday.
- ì Press “Confirm” button to save the setting; press “Cancel” button to cancel the setting.
- ì Press “System Setting” button again until “⌚” displays on the screen.
- ì Press “◀” button to set hour, press “▶” button to set minute.
- ì Press “Confirm” button to save the setting; press “Cancel” button to cancel the setting.

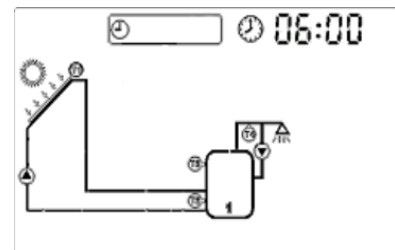
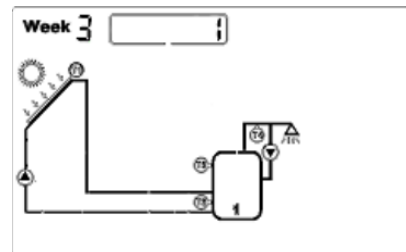

2. Selecting a system

- ì Press “System Setting” button until the signal “” displays on the screen.
- ì Press “◀” “▶” button to select a system.
- ì Press “Confirm” button to confirm the setting.
- ì Press “Cancel” button to cancel the setting.

3. Temperature difference circulation function

The solar control program works on the principle of temperature difference circulation. Solar pump P1 is triggered, as soon as the preset temperature difference between collector and storage is reached. If there is more than one storage or one collector array, system will compare the temperature difference between collectors and storage automatically.

- ì Press “System Setting” button, until “” displays on the screen.
- ì Press “◀” “▶” button to adjust storage temperature. Default value: 60 °C, setting range: 45~75 °C.
- ì Press “Confirm” button to save the setting. Press “Cancel” button to cancel this function.
- ì At the same time the menu shows “10 °C”, the default value of switch-on temperature difference.
- ì Press “◀” “▶” button to adjust it. Setting range: 5~20 °C.
- ì Press “Confirm” button to save the setting. Press “Cancel” button to cancel this function.
- ì Then the menu shows “5 °C”, the default value of switch-off temperature difference.
- ì Press “◀” “▶” button to adjust it, adjustable range: 2~12 °C.

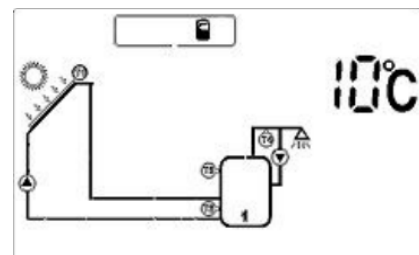





- ì Press “Confirm” button to confirm the setting. Press “Cancel” button to cancel the function.

Note: Between 60~70 scale can form more easily; we usually set the storage temperature at 60 .

4. Time-controlled auxiliary heating

Solar thermal system can be combined with electric boiler or gas/oil boiler. The system is supported with a default program which can be customized to meet your individual needs. You can create a timer program with up to three time periods to heat the water to a desired value. During the three preset time periods, auxiliary heating starts working, when the water temperature in top part of storage (T3) is below preset turning-on temperature, and it stops working, when T3 exceeds the required temperature.

Note: Default setting: the first time period: 04:00 turning-on, 05:00 turning-off; the second time period: 10:00~10:00; the third time period: 17:00 turning-on, 22:00 turning-off.

- ì Press “System Setting” button until the signal “” appears.
- ì Press “ ” button to set the start time of the first time period. Press “” to adjust hours, press “” button to adjust minutes.
- ì Press “Confirm” button to save the settings, press “Cancel” button to cancel the settings.
- ì Immediately after setting the first time period, the display enters into the operating menu of next time period.
- ì Perform like above steps, the other two time periods can be set.

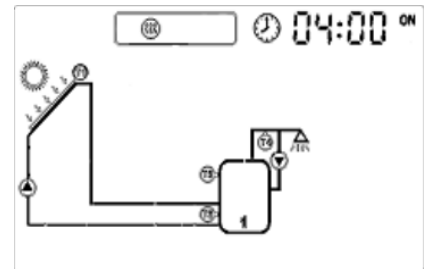





Note: If you want to shut off one of the three time periods, you can set a same value for both start time and ending time, e.g., you can set both the start and ending time of second time period at 10:00 am.

5. Time-controlled circulation function

This function needs an extra circulation pump (P2). You can set up a timer program with up to three time periods. This pump can be triggered at times when hot water will be needed.

Note: Within the preset three time periods, pump P2 always stops for 15 minutes after operating for 3 minutes.

Note: Default setting: the first time period: 06:00 turning-on, 08:00 turning-off; the second time period: 10:00~10:00; the third time period: 19:00 turning-on, 21:00 turning-off. Three time periods should be set within one day (24 hours).

- ì Press “System Setting”, until “” displays on the screen.
- ì Press “ ” button to adjust the start time and end time of first time period. Press “” button to adjust hours, press “” button to adjust minutes.

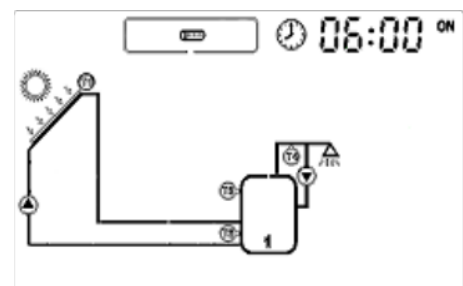

- ì Press “Confirm” button to confirm the setting, press “Cancel” button to cancel this setting.
- ì Immediately after setting the first time period, the display enters into the operating menu of next time period.
- ì Perform like above steps, the other two time periods can be set.



Note: If you want to shut off one of the three time periods, you can set a same value for both start time and ending time, e.g., you can set both the start and ending time of second time period at 10:00 am.

6. Temperature-controlled circulation function

Solar system provides temperature-controlled hot water circulation function. This function needs an extra hot water circulation pump (P2) and a sensor (T4). When the temperature of T4 falls below the preset temperature value, the circulation pump (P2) starts operating, until the temperature exceeds the preset temperature.

- ì Press “Choose Function”, until “” displays on the screen.
- ì Press “◀” “▶” button to adjust the temperature value, default value: 40 , setting range: 20~50 . Press “◀” button to adjust hours, press “▶” button to adjust minutes.
- ì Press “Confirm” button to confirm the setting, press “Cancel” button to cancel this setting.

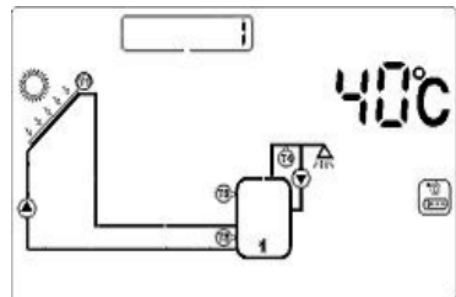

Note: In order to avoid measuring error, the position of sensor T4 should be minimum 1.5m far from the storage.



7. Switching on/off auxiliary heating manually

If you want to use warm water immediately, but the water temperature doesn't reach the desired value, you can switch on/off the auxiliary heating manually.

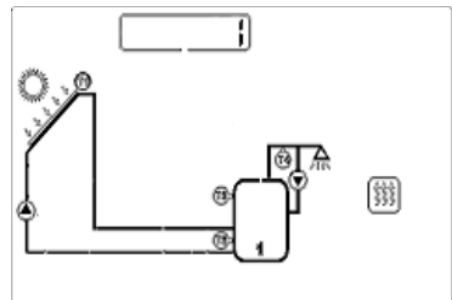
- ì Press “confirm” button, until “” displays on the screen to switch on auxiliary heating manually.
- ì Press “Cancel” button to switch off auxiliary heating manually.



8. Forbid/Permit using auxiliary heating

- ì Press “Choose Function” button, until “” displays on the screen.
- ì Press “Confirm” button to save the setting and forbid auxiliary heating.
- ì Press “Choose Function” button until “” displays on the screen.
- ì Press “Cancel” button to cancel the setting and permit auxiliary heating.

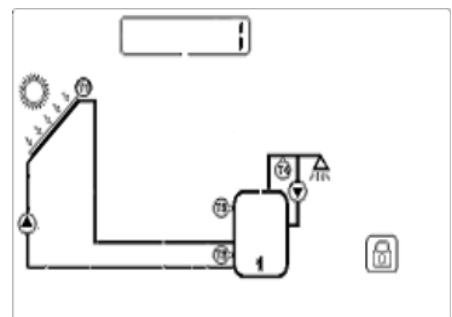



Note: When forbid auxiliary heating, customer can't switch on/off auxiliary heating manually and time-controlled auxiliary heating function is also automatically deactivated.

9. Frost protection

In winter, when the temperature of collector drops below the preprogrammed starting temperature of frost protection (default value 5 °C), solar pump P1 starts working. When collector temperature exceeds the switch-off temperature of frost protection, pump P1 stops working and the system exits frost protection.

- ì Press “Choose Function”, until “” displays on the screen.
- ì Press “◀” “▶” button to adjust the temperature of frost protection. Setting range: 3 °C –10 °C .
- ì Press “Confirm” button to confirm the setting, press “Cancel” button to deactivate this function.

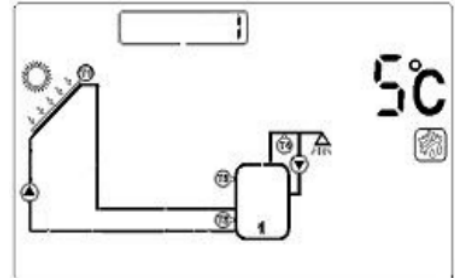

10. Storage overheating protection

To avoid overheating of water storage, system is supported with an overheating protection function. When the temperature of storage (T3) is higher than the maximum temperature, even the condition of temperature difference circulation is reached, solar pump is still forbidden to operate.

- ì Press “Choose Function” button, until “” displays on the screen.
- ì Press “◀” “▶” button to adjust the maximum storage temperature. Default value: 80 °C , setting range: 60–90 °C .
- ì Press “Confirm” button to confirm the setting, press “Cancel” button to quit the function.

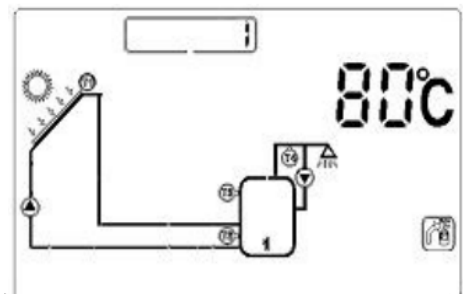

11. High temperature protection of solar system

When collector temperature reaches 115 °C , and meanwhile the storage doesn't reach the max. temperature, the high temperature protection function of solar system will be activated.

- ì Press “Choose Function”, until “” displays on the screen.
- ì Press “◀” “▶” button to adjust the maximum collector temperature. Default value: 115 °C , setting range: 100–130 °C .
- ì Press “Confirm” button to confirm the setting, press “Cancel” button to quit this function.

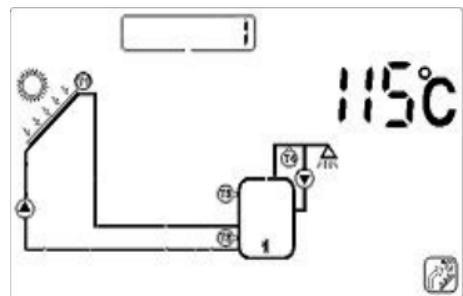

12. Recooling the system by through by-pass

This function can realize recooling the solar system through an extra installed radiator (by-pass).



Attention: The by-pass is controlled by corresponding electromagnetic 3-way valve R2, but the operation menu

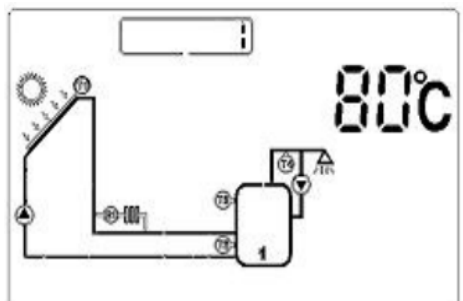

shows R1, it's an error indication!

- ì Press “Choose Function”, until “” displays on the screen.
- ì Press “◀” “▶” button to adjust the switch-on temperature (T1). Default value: 80 , setting range: 60~90 .
- ì Press “Confirm” button to confirm the setting, press “Cancel” button to quit this function.

13. Extended temperature-difference circulation function

The Following described function can extend a simple “1 collector array-1 storage” solar system with an additional temperature difference circulation.



Note: Only if the input T0, T5 and output R2 are not occupied, this function can be activated.

- ì Press “Choose Function”, until “” displays on the screen.
- ì Press “Confirm” button to activate this function. Press “Cancel” button to quit this function.

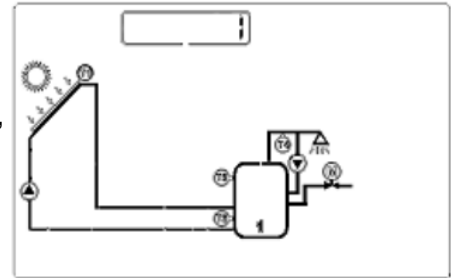

14. Holiday function

If you intend to be absent for an extended period (holiday), or hot water is not required for an extended period, you can activate the holiday function. This function is activated nightly (22 : 00-06 : 00) to re-cool the storage and to prevent high thermal loads of the solar system due to completely heated storage.

- ì Press “Choose Function”, until “” displays on the screen, it indicates that the function is active.
- ì Press “Confirm” button to confirm this setting. Press “Cancel” button to deactivate this function.

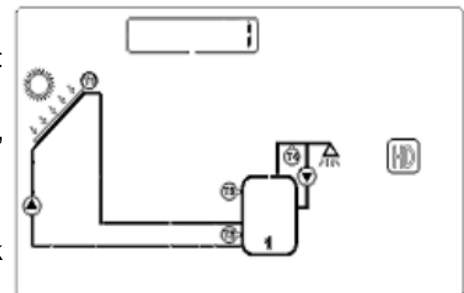

Note: When using holiday function, system will lock auxiliary heating automatically.

15. Anti-bacteria protection

To safeguard the water hygiene, solar system will monitor the storage temperature. If the temperature never reaches 70 in every 7 days, auxiliary heating will be activated automatically and heats the storage temperate to 70 .

16. Collector emergency cut-off

When the temperature of collector reaches or exceeds 120 , in order to prevent evaporation of heat medium liquid and protect other components of solar system, solar circulation pump will be stopped compulsively, until the temperature of collector gets lower.

17. Memory function

In case of power failure, solar control system is able to remain the preset parameters unchanged.

18. Reset Function

If necessary, all the settings (except time setting) can be reset to the factory settings.

- i Press “Choose Function” button, until “AUTO” displays on the screen.
- i Press “Confirm” button, all of parameters will be reset to factory settings.

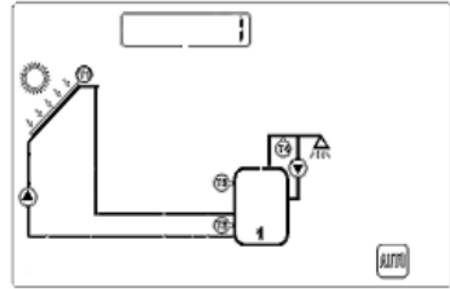

19. Manual operations

Customers can monitor the flow rate anytime by viewing the signal “000 L/M” on main operating menu. And when there are no other operations and it returns to main menu, they can also activate some functions by pressing different buttons directly.

- i Press “Confirm” button to switch on/off solar collector pump (P1) manually.
- i Press “Cancel” button to switch on/off solar hot water circulation pump (P2) manually.
- i Press “◀ ▶” button repeatedly to check the temperature values in different part of solar system.

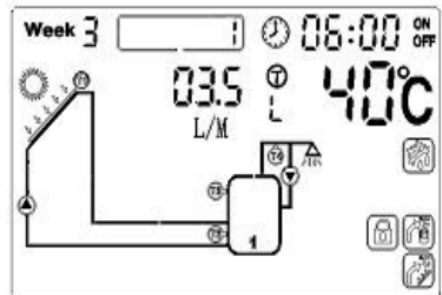

Fault messages



Danger: Never try to repair the solar pumping station yourself! Consult a specialist in case of an error.

The following table explains the error messages and corresponding handling indication. Most of the problems can be found in the list below.

No.	Familiar problem	Possible reason	Solution
1	Pump works but no flow rate displays.	There is probably too much air in the pipeline.	Replenish heat medium liquid and exhaust the air.
2	System has temp. difference but pump doesn't work.	Storage reaches max. temp.	When storage temperature drops, pump starts working.
		Solar collector reaches its max. temp..	When collector temperature drops, pump starts working.
3	Pump doesn't work, and the signal “①” blinks.	There is probable broken circuit or short circuit with temperature sensors.	Check the sensor wiring and replace sensors if necessary.
4	Auxiliary heating doesn't work.	Auxiliary heating is forbidden.	Activate it manually.
		Temperature sensor has broken circuit or short circuit.	Check sensor connection and make the wiring again.
5	Auxiliary heating still operates at 23:00.	Anti-bacteria function starts up.	It's normal.

6	System pressure drops.	There is air leakage in solar system.	Check the pipeline and exhaust the air.
7	Pump works but system doesn't have temp. difference,	Frost function is activated.	No error.
		Holiday function is activated.	

The solar work station SP118 shows error messages in the main operating menu if there is a problem with temperature sensor.

Error message	meaning	Possible cause	Error rectification
<FF >	There is broken circuit with sensor connections.	Sensor wiring interrupted, not connected or short circuit.	Check resistance value, replace sensor if necessary.
<FE >	There is a short circuit with sensor connections.	Sensor wiring interrupted, not connected or short circuit.	Check resistance value, replace sensor if necessary.



Note: A potentially defective sensor can be checked using an ohmmeter. To do this, the sensor must be disconnected. Its resistance value can be compared with the figures below, small deviation is acceptable.

PT1000 resistance value

	0	10	20	30	40	50	60	70	80	90	100	110	120
	1000	1039	1077	1116	1155	1194	1232	1270	1309	1347	1385	1422	1460

NTC 10K B=3950 resistance value

	0	10	20	30	40	50	60	70	80	90	100	110	120
	33620	20174	12535	8037	5301	3588	2486	1759	1270	933	697	529	407

Part 2: Installation instruction

General information

1. Safety

Before installing the device, please read this manual carefully. Please note that the installation must be executed according to relevant technical rules. The installation must be adapted to the conditions provided by the customer. Damages by improper using or incorrect modification of installation and construction are on costumer site.

⚠ Attention: This manual is for trained personals only!

! Note: As faults can never be excluded, we don't offer a guarantee for the completeness of the drawings and texts of this manual, they only represent some examples.

2. Input and output signals

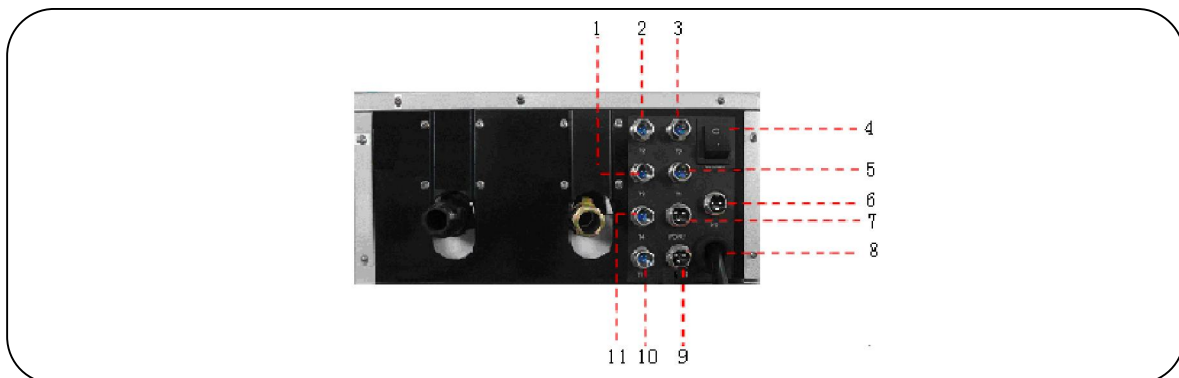

1	T3 connector	7	P0 pump or R1 electromagnetic 3-way valve
2	T2 connector	8	Power cord and auxiliary heating connection
3	T0 connector	9	R2 electromagnetic 3-way valve
4	Power switch	10	T5 connector
5	T1 connector	11	T4 connector
6	P2 pump		

3. System demonstration

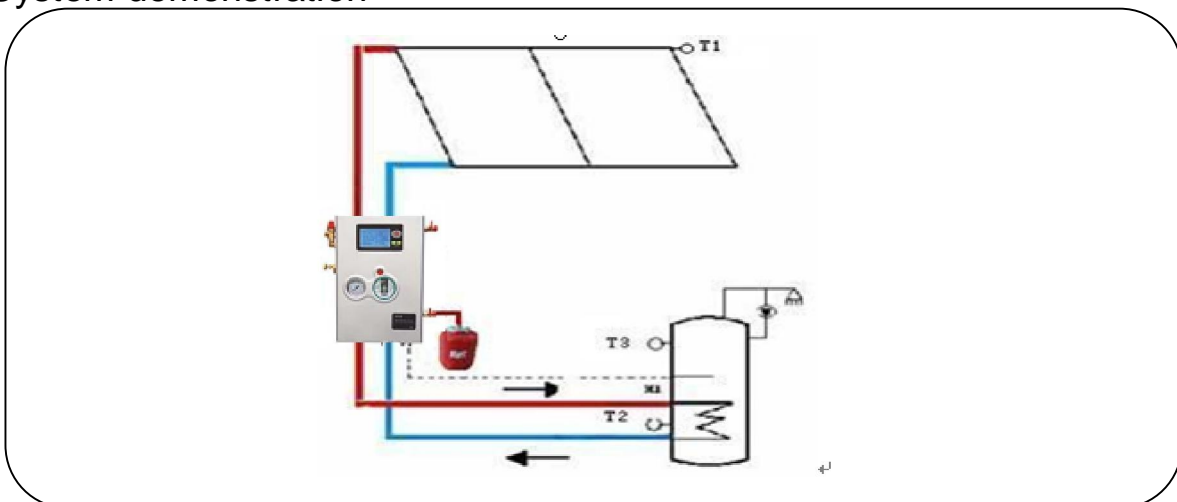

Mounting

1. Open the package carton and take out the solar control system carefully.

Determine the mounting position of the solar control system, considering the mounting place for expansion vessel. See picture 1.

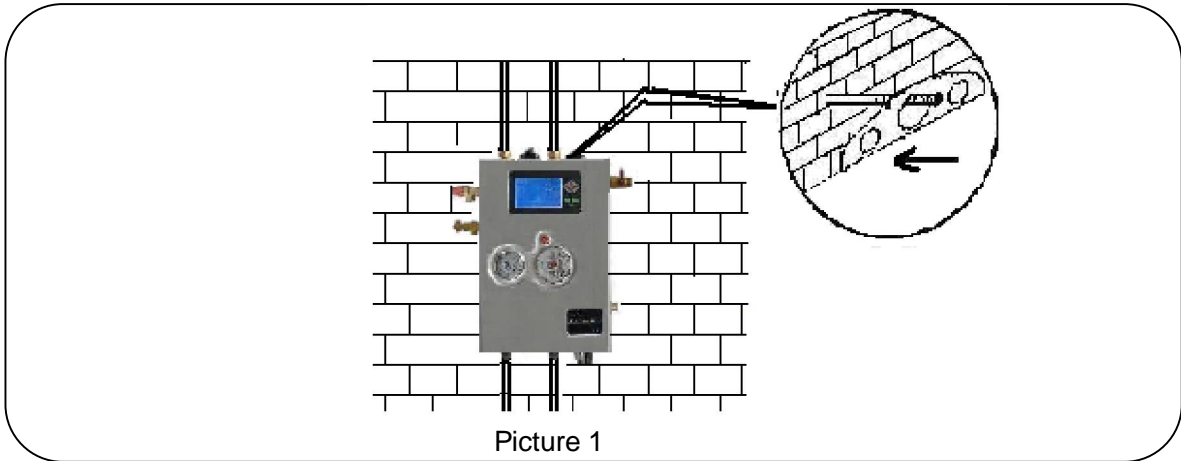

2. Drill the holes for dowels, put the dowels into the holes, fixed the solar control system on the wall using fastening screws. The solar control system must be vertically installed. See picture 2.

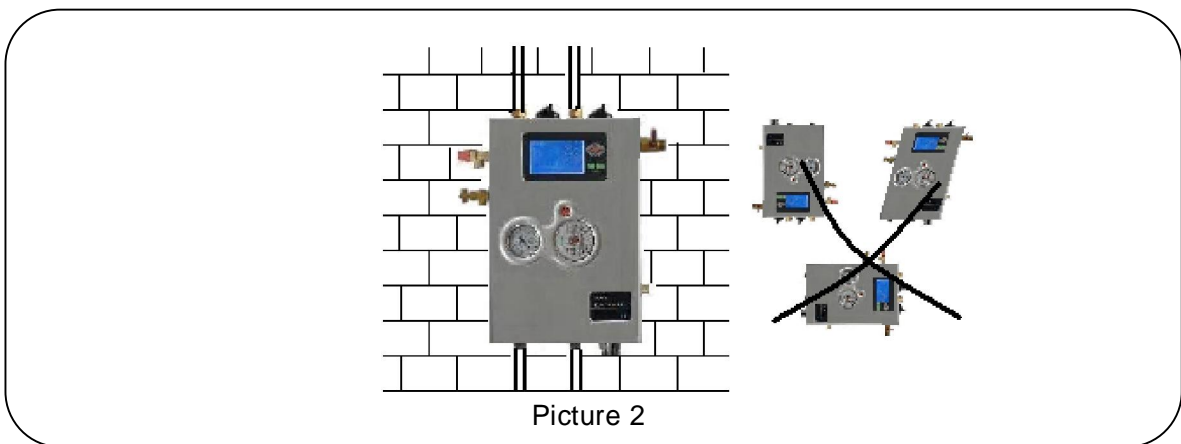

3. Use two wrenches to connect the pipes. See picture 3.

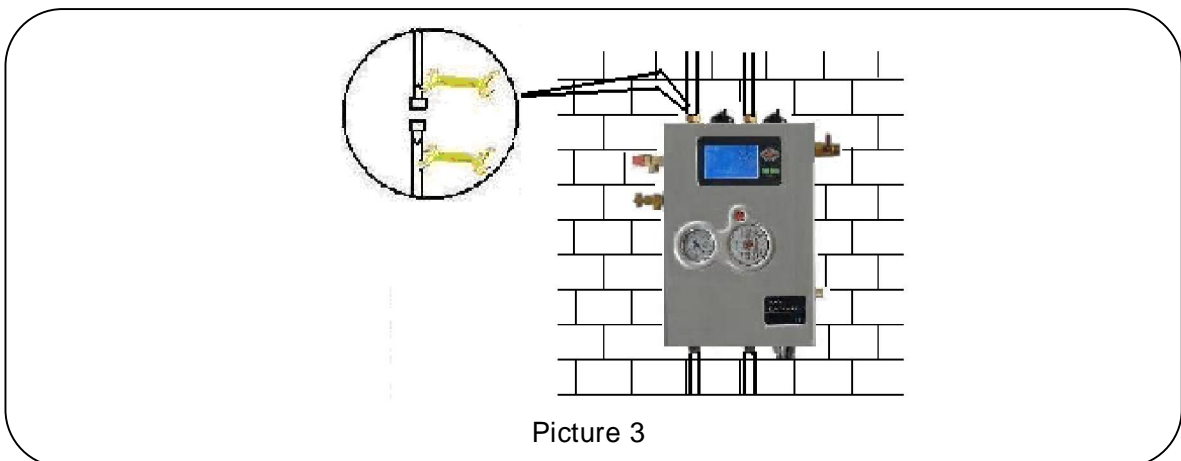

- Determine the mounting place for the expansion vessel. Connect the expansion vessel. See picture5.

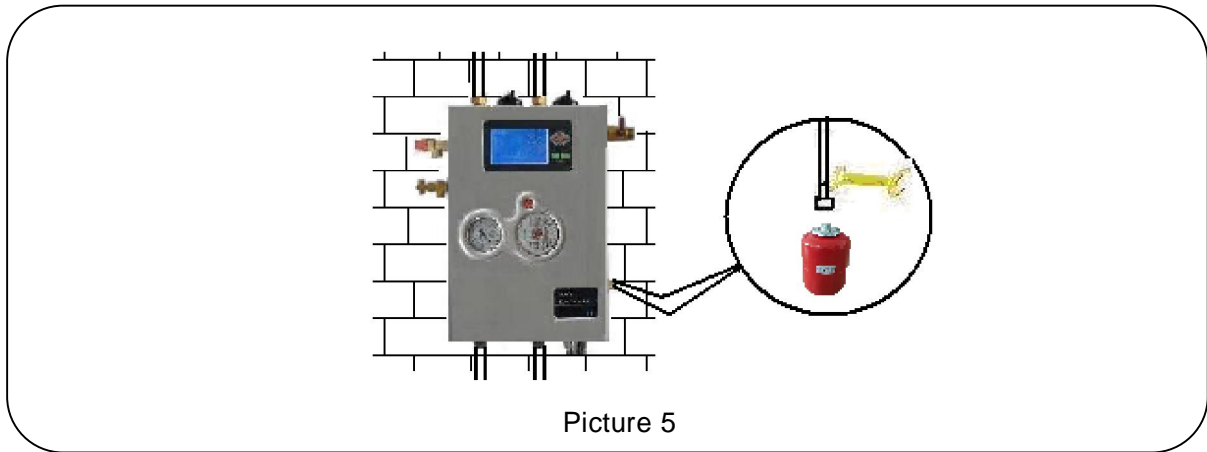

5. Filling the system

Open the air vent valve.

Open the filling connector (1) and connect a separate pump to the system with pressure hose. The heat medium liquid (usually use water-glycol mixture as heat medium, 50% glycol and 50% water) will be pumped into the system until it overflows through the air vent valve.

Close the air vent valve and continue to fill the system with medium liquid until the system pressure is not lower than 2 bar (the system pressure can be read from the manometer).

Close the filling connector and switch off the pump.

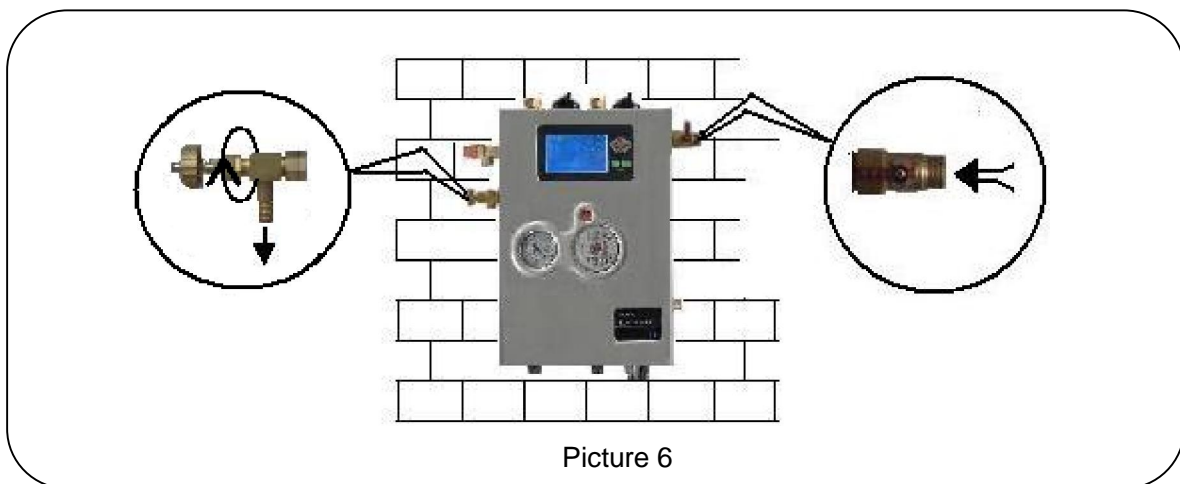

Electrical wiring

- Insert the temperature sensors into storage and solar collector. Connect these sensors to the work station correspondingly. See picture 7.

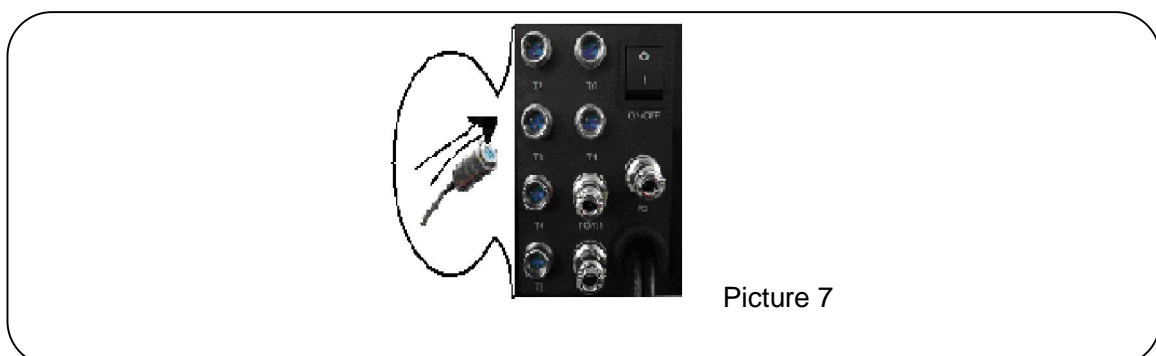

2. Connect auxiliary heating wire if available. Cable (coffee) for the “L”, cable (blue) for “N” line, cable (yellow-green) for the ground wire.

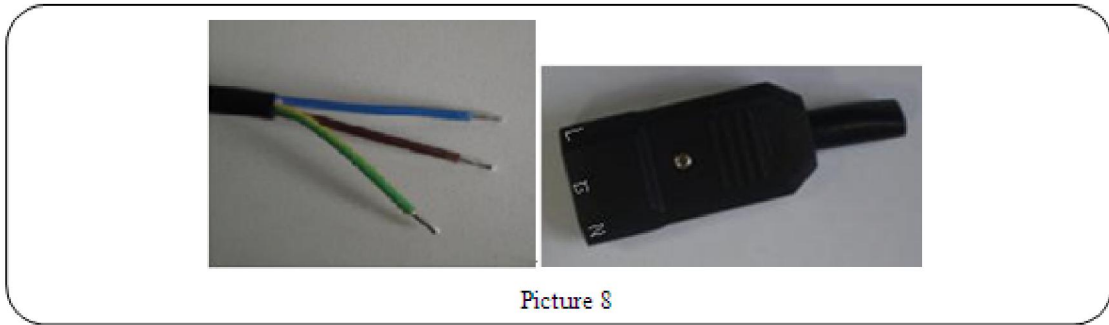

3. To connect external circulation pumps or any electromagnetic valves, firstly loose the aviation socket and dismount it as indicated below. Connect the wire to aviation socket, number 1 connects “N” wire, number 2 connects ground wire, number 3 connects “L” wire. Reassemble the aviation socket and connect it to the solar control system.



4. Tighten all joints and screw connections. Then plug the power supply into a socket.

Commissioning

1. Switch on the power of solar control system. Press “Confirm” button (in main operating menu) to activate the solar collector pump (P1) manually and let the system circulate for a moment. See picture 10.

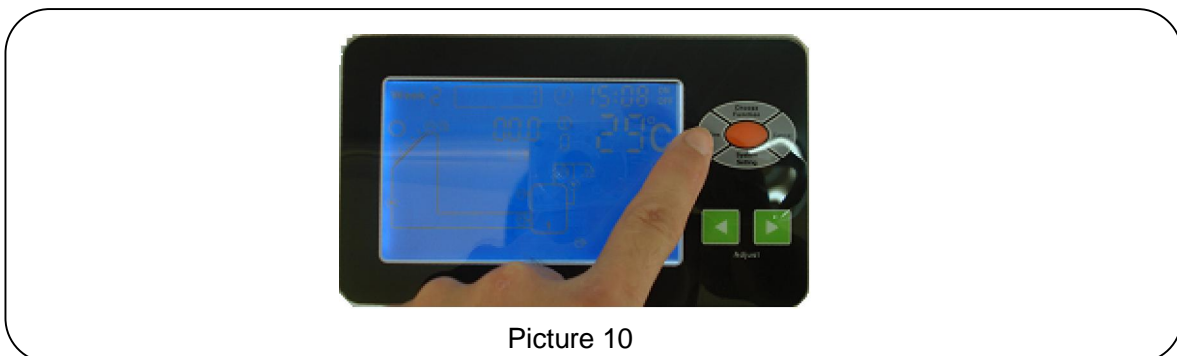

2. Observe the flow rate of solar control system which displays on LCD screen. If the flow rate is not regular, it indicates that there must be air still in the system. Open the air vent valve several times to relief the air.

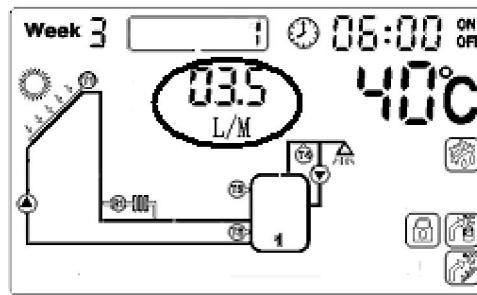

Picture 11

3. When the flow rate becomes regular, observe the system pressure from manometer. If the pressure is lower than 2 bars, refill the system with heat medium to increase the pressure.



Picture 12

4. Carry out a pressure test of all system joints again for leaks. The solar system must be vented several times after some operating hours. Refill the system if necessary.
5. Refill the system if necessary.
6. Remove the separate pump for filling after commissioning.
7. If there is auxiliary heating wire connected, press “Choose Function” button until “” signal displays on screen. It means switch on auxiliary heating manually. Then customer can use auxiliary heating function.

Replace the pump

1. The integrated solar collector pump could be replaced if it gets broken. Disconnect the power supply of solar control system. Loose the screw and open the metal cover.

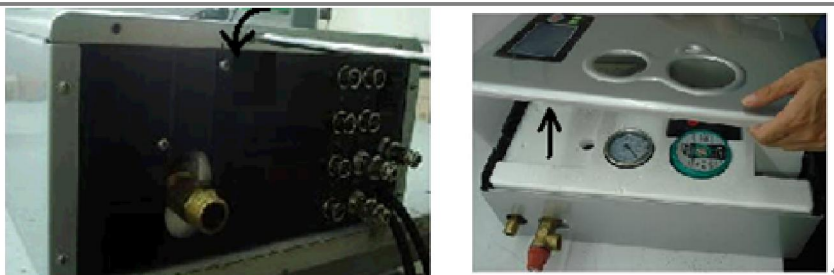

Picture 13

2. Remove the front half of the insulation material from system



Picture 14

3. Open the terminal box, and disconnect the power supply connection.

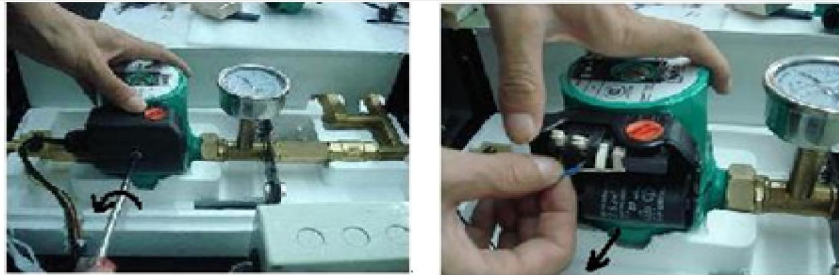

Picture 15

4. Loosen the screws and open the WILO pump.



Picture 16

5. Replace the old one with a new WILO pump.

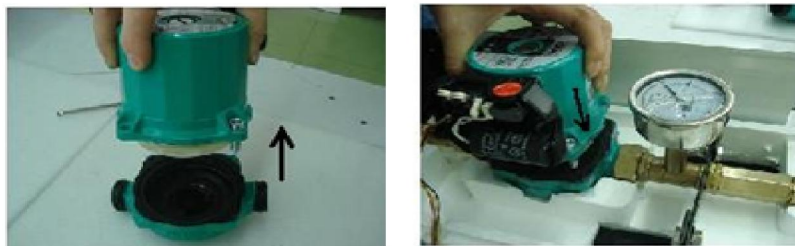

Picture 17

6. Fasten the WILO pump screws.



Picture 18

7. Connect the power supply again and close the terminal box.

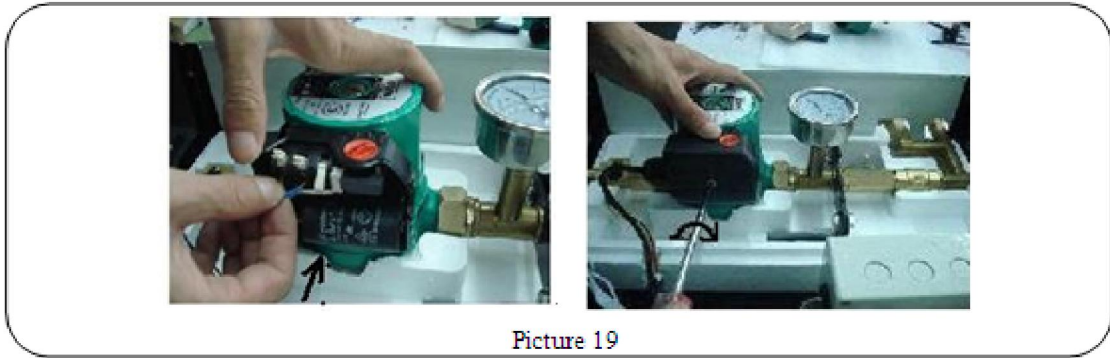

Picture 19

8. Attach the front half the foam cover.



Picture 20

9. Attach the meal cover and fasten the screws again.

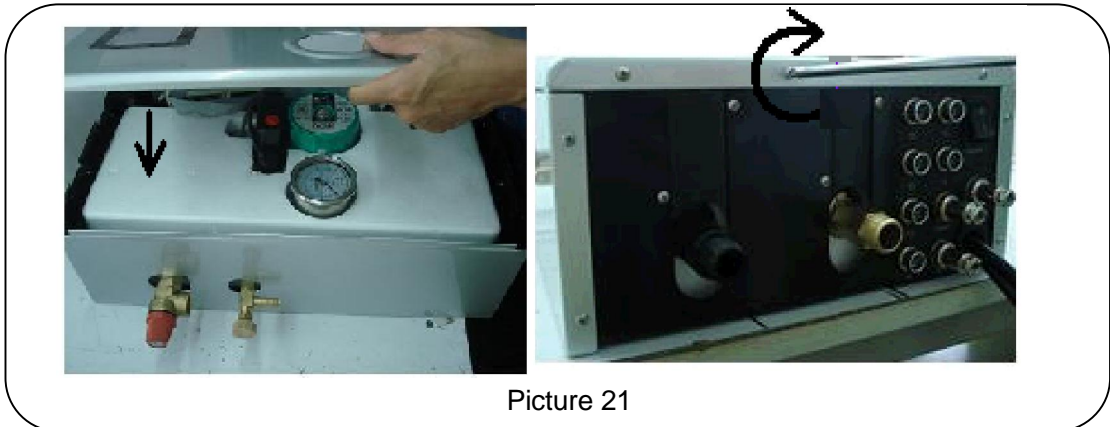

Picture 21

Packing list

No.	Item	Specification	Quantity
1	Work station	450x310x150mm	1 pc
2	Power line		1 pc
3	PT1000 sensor	15m	2 pcs
4	NTC sensor	3m	4 pcs
5	Fixed screw		1 bag
6	Manual		1 pc